

TEST REPORT

CERTIFICATE OF CONFORMITY

Standard: 47 CFR FCC Part 15, Subpart B, Class B

ANSI C63.4-2014

ANSI C63.4a-2017

Report No.: FDCDVB-WTW-P24030649

Product: Keyboard Dock, Detachable Keyboard

Brand: Getac

Model No.: K120-Keyboard Dock 3.0, K120-Detachable Keyboard 3.0 (refer to item 3.1 for more details)

Received Date: 2024/3/29

Test Date: 2024/4/18 ~ 2024/4/24

Issued Date: 2024/7/3

Applicant: Getac Technology Corporation.

Address: 5F., Building A, No. 209, Sec, Nangang Rd., Nangang Dist., Taipei City 11568, Taiwan, R.O.C.

Issued By: Bureau Veritas Consumer Products Services (H.K.) Ltd., Taoyuan Branch
Lin Kou Laboratories

Lab Address: No. 47-2, 14th Ling, Chia Pau Vil., Lin Kou Dist., New Taipei City, Taiwan

Test Location: No. 19, Hwa Ya 2nd Rd., Wen Hwa Vil., Kewi Shan Dist., Taoyuan City 33383, Taiwan

FCC Registration / 328930 / TW1050

Designation Number:

Approved by: _____

Leo Hsu

Date: _____

2024/7/3

Leo Hsu / Project Engineer

This test report consists of 21 pages in total. It may be duplicated completely for legal use with the approval of the applicant. It should not be reproduced except in full, without the written approval of our laboratory. The test results in the report only apply to the tested sample. The test results in this report are traceable to the national or international standards.



Prepared by : Lena Wang / Specialist

This report is governed by, and incorporates by reference, the Conditions of Testing as posted at the date of issuance of this report at <http://www.bureauveritas.com/home/about-us/our-business/cps/about-us/terms-conditions/>, and is intended for your exclusive use. Any copying or replication of this report to or for any other person or entity, or use of our name or trademark, is permitted only with our prior written permission. This report sets forth our findings solely with respect to the test samples identified herein. The results set forth in this report are not indicative or representative of the quality or characteristics of the lot from which a test sample was taken or any similar or identical product unless specifically and expressly noted. Our report includes all of the tests requested by you and the results thereof based upon the information that you provided to us. Measurement uncertainty is only provided upon request for accredited tests. Statements of conformity are based on simple acceptance criteria without taking measurement uncertainty into account, unless otherwise requested in writing. You have 60 days from date of issuance of this report to notify us of any material error or omission caused by our negligence or if you require measurement uncertainty; provided, however, that such notice shall be in writing and shall specifically address the issue you wish to raise. A failure to raise such issue within the prescribed time shall constitute your unqualified acceptance of the completeness of this report, the tests conducted and the correctness of the report contents.

Table of Contents

Release Control Record	3
1 Certificate.....	4
2 Summary of Test Results	5
2.1 Measurement Uncertainty	5
2.2 Supplementary Information	5
3 General Information	6
3.1 Description of EUT	6
3.2 Primary Clock Frequencies of Internal Source.....	6
3.3 Features of EUT	6
3.4 Operating Modes of EUT and Determination of Worst Case Operating Mode	6
3.5 Test Program Used and Operation Descriptions	7
3.6 Connection Diagram of EUT and Peripheral Devices	8
3.7 Configuration of Peripheral Devices and Cable Connections	9
4 Test Instruments	10
4.1 Conducted Emissions from Power Ports	10
4.2 Radiated Emissions up to 1 GHz	11
5 Limits of Test Items.....	12
5.1 Conducted Emissions from Power Ports	12
5.2 Radiated Emissions up to 1 GHz	12
6 Test Arrangements.....	13
6.1 Conducted Emissions from Power Ports	13
6.2 Radiated Emissions up to 1 GHz	14
7 Test Results of Test Item	15
7.1 Conducted Emissions from Power Ports	15
7.2 Radiated Emissions up to 1 GHz	17
8 Pictures of Test Arrangements	19
8.1 Conducted Emissions from Power Ports	19
8.2 Radiated Emissions up to 1 GHz	20
9 Information of the Testing Laboratories	21



Release Control Record

Issue No.	Description	Date Issued
FDCDVB-WTW-P24030649	Original release.	2024/7/3

1 Certificate

Product: Keyboard Dock, Detachable Keyboard

Brand: Getac

Test Model: K120-Keyboard Dock 3.0, K120-Detachable Keyboard 3.0 (refer to item 3.1 for more details)

Sample Status: Engineering Sample

Applicant: Getac Technology Corporation.

Test Date: 2024/4/18 ~ 2024/4/24

Standard: 47 CFR FCC Part 15, Subpart B, Class B
ANSI C63.4–2014
ANSI C63.4a–2017

The above equipment has been tested by **Bureau Veritas Consumer Products Services (H.K.) Ltd., Taoyuan Branch**, and found compliance with the requirement of the above standards. The test record, data evaluation & Equipment Under Test (EUT) configurations represented herein are true and accurate accounts of the measurements of the sample's EMC characteristics under the conditions specified in this report.

2 Summary of Test Results

The test items that the EUT need to perform in accordance with its interfaces, evaluated functions, are as follows:

Standard / Clause	Test Item	Result	Remark
FCC Part 15.107	Conducted Emissions from Power Ports	Pass	Minimum passing Class B margin is -7.73 dB at 13.56000 MHz
FCC Part 15.109	Radiated Emissions up to 1 GHz	Pass	Minimum passing Class B margin is -3.38 dB at 148.50 MHz

Note: Determining compliance based on the results of the compliance measurement, not taking into account measurement instrumentation uncertainty.

2.1 Measurement Uncertainty

Where relevant, the following measurement uncertainty levels have been estimated for tests performed on the EUT as specified in CISPR 16-4-2:

Measurement	Specification	Expanded Uncertainty (k=2) (±)	Maximum allowable uncertainty (±)
Conducted Emissions from Power Ports	9 kHz ~ 30 MHz	2.88 dB	3.4 dB (U_{CISPR})
Radiated Emissions up to 1 GHz	30 MHz ~ 1 GHz	4.69 dB	6.3 dB (U_{CISPR})

The other instruments specified are routine verified to remain within the calibrated levels, no measurement uncertainty is required to be calculated.

2.2 Supplementary Information

There is not any deviation from the test standards for the test method, and no modifications required for compliance.

3 General Information

3.1 Description of EUT

Product	Keyboard Dock, Detachable Keyboard
Brand	Getac
Test Model	K120-Keyboard Dock 3.0, K120-Detachable Keyboard 3.0
Sample Status	Engineering Sample
Power Supply Rating	5 Vdc / 9 Vdc / 12 Vdc / 15 Vdc / 19 Vdc / 20Vdc(adapter)

Note: All models are listed as below.

Brand	Product	Model	Difference
Getac	Keyboard Dock	K120-Keyboard Dock 3.0	With I/O port: HDMI, type-c, USB, DC Jack, RS-232, Display port, LAN port
	Detachable Keyboard	K120-Detachable Keyboard 3.0	Only type-c and DC Jack

3.2 Primary Clock Frequencies of Internal Source

The highest frequency generated or used within the EUT or on which the EUT operates or tunes is 25 MHz, provided by Getac Technology Corporation., for detailed internal source, please refer to the manufacturer's specifications.

3.3 Features of EUT

The tests reported herein were performed according to the method specified by Getac Technology Corporation., for detailed feature description, please refer to the manufacturer's specifications or user's manual.

Please refer to appendix of the report if the applicant has provided additional descriptions of the EUT.

3.4 Operating Modes of EUT and Determination of Worst Case Operating Mode

The EUT has been pre-tested under following test modes.

Test Condition	
Mode	Conducted Emissions from Power Ports
1	Tablet resolution (1920*1080@60Hz) + bt link + wifi 2.4g link + HDMI with monitor resolution (3840*2160@60Hz) + type-c with hdd *2 + usb with m/s + ic card link + nfc link + sd card + camera + earphone + touch pen + scanner + lan 1Gbps link + gps rx + battery *2 + EUT docking 1 [usb with printer + HDMI with monitor resolution (3840*2160@60Hz) + usb with hdd*2 + rs232 with modem + lan 1Gbps link + dp with monitor resolution (3840*2160@60Hz) + usb-c with adapter 1]
2	Tablet resolution (1920*1080@60Hz) + bt link + wifi 2.4g link + HDMI with monitor resolution (3840*2160@60Hz) + type-c with hdd *2 + usb with m/s + ic card link + nfc link + sd card + camera + earphone + touch pen + scanner + lan 1Gbps link + gps rx + battery *2 + EUT docking 1 [usb with printer + HDMI with monitor resolution (3840*2160@60Hz) + usb with hdd*3 + rs232 with modem + lan 1Gbps link + dp with monitor resolution (3840*2160@60Hz) + adapter 2]
3	Tablet resolution (1920*1080@60Hz) + bt link + wifi 2.4g link + HDMI with monitor resolution (3840*2160@60Hz) + type-c with hdd *2 + usb with m/s + ic card link + nfc link + sd card + camera + earphone + touch pen + scanner + lan 1Gbps link + gps rx + battery *2 + EUT docking 2 [usb-c with adapter 1]

Notes:

1. There are both AC 120V/60Hz and AC 240V/60Hz to be pre-tested then AC 120V/60Hz has the highest emission value.
2. The worst case is that mode 1 is shown in bold.

Mode	Radiated Emissions up to 1 GHz
1	Tablet resolution (1920*1080@60Hz) + bt link + wifi 2.4g link + HDMI with monitor resolution (3840*2160@60Hz) + type-c with hdd *2 + usb with m/s + ic card link + nfc link + sd card + camera + earphone + touch pen + scanner + lan 1Gbps link + gps rx + battery *2 + EUT docking 1 [usb with printer + HDMI with monitor resolution (3840*2160@60Hz) + usb with hdd*2 + rs232 with modem + lan 1Gbps link + dp with monitor resolution (3840*2160@60Hz) + usb-c with adapter 1]
2	Tablet resolution (1920*1080@60Hz) + bt link + wifi 2.4g link + HDMI with monitor resolution (3840*2160@60Hz) + type-c with hdd *2 + usb with m/s + ic card link + nfc link + sd card + camera + earphone + touch pen + scanner + lan 1Gbps link + gps rx + battery *2 + EUT docking 1 [usb with printer + HDMI with monitor resolution (3840*2160@60Hz) + usb with hdd*3 + rs232 with modem + lan 1Gbps link + dp with monitor resolution (3840*2160@60Hz) + adapter 2]
3	Tablet resolution (1920*1080@60Hz) + bt link + wifi 2.4g link + HDMI with monitor resolution (3840*2160@60Hz) + type-c with hdd *2 + usb with m/s + ic card link + nfc link + sd card + camera + earphone + touch pen + scanner + lan 1Gbps link + gps rx + battery *2 + EUT docking 2 [usb-c with adapter 1]
Note: The worst case is that mode 1 is shown in bold.	

Test modes are presented in the report as below.

Test Condition	
Mode	Conducted Emissions from Power Ports
-	Tablet resolution (1920*1080@60Hz) + bt link + wifi 2.4g link + HDMI with monitor resolution (3840*2160@60Hz) + type-c with hdd *2 + usb with m/s + ic card link + nfc link + sd card + camera + earphone + touch pen + scanner + lan 1Gbps link + gps rx + battery *2 + EUT docking 1 [usb with printer + HDMI with monitor resolution (3840*2160@60Hz) + usb with hdd*2 + rs232 with modem + lan 1Gbps link + dp with monitor resolution (3840*2160@60Hz) + usb-c with adapter 1]
Mode	Radiated Emissions up to 1 GHz
-	Tablet resolution (1920*1080@60Hz) + bt link + wifi 2.4g link + HDMI with monitor resolution (3840*2160@60Hz) + type-c with hdd *2 + usb with m/s + ic card link + nfc link + sd card + camera + earphone + touch pen + scanner + lan 1Gbps link + gps rx + battery *2 + EUT docking 1 [usb with printer + HDMI with monitor resolution (3840*2160@60Hz) + usb with hdd*2 + rs232 with modem + lan 1Gbps link + dp with monitor resolution (3840*2160@60Hz) + usb-c with adapter 1]

3.5 Test Program Used and Operation Descriptions

- The Tablet was charged from adapter through EUT.
- The Tablet sent "H" patterns to monitor, and external monitor displayed them via HDMI / DP Cable through EUT.
- The Tablet use "Burn-in test" test program to read and written data with external HDD via USB / USB Type C cable through EUT, and data is read and written with the internal HDD / SD Card.
- The Tablet sends sound signals to the earphone.
- The Tablet executes " Diagnostic_tool " program to read the IC Card.
- The EUT and Tablet sent and received messages to remote Laptop via LAN cable.
- The Tablet connected to the modem via RS232 cable to send and receives data through EUT.
- The Tablet executes " Barcode " program to read the Barcode.
- The Tablet linked with Bluetooth Earphone.
- The Tablet communicated data with the AP router / GPS simulator which acted as a communication partner.
- The Tablet reading NFC tag.
- The Tablet camera was activated.

3.6 Connection Diagram of EUT and Peripheral Devices

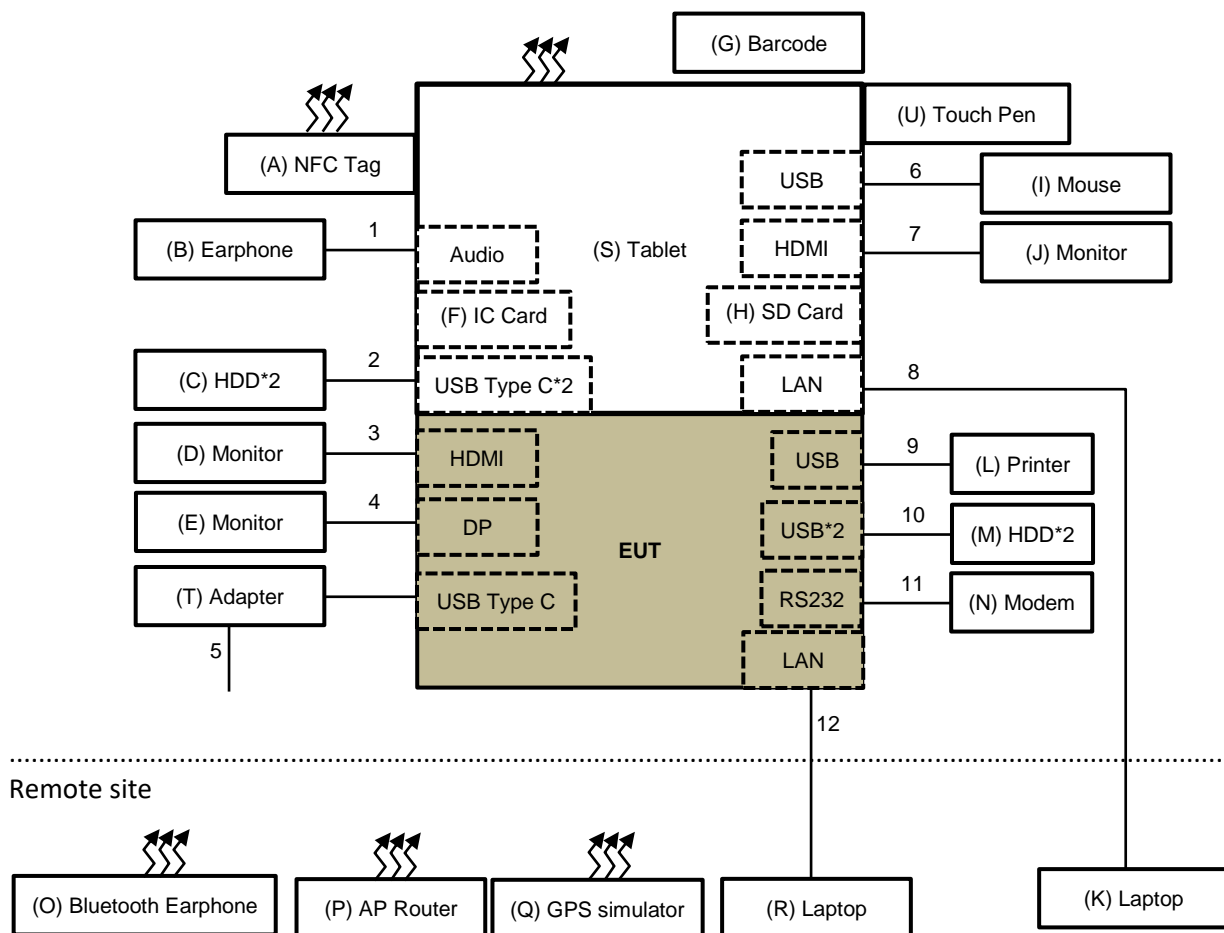

3.7 Configuration of Peripheral Devices and Cable Connections

ID	Product	Brand	Model No.	Serial No.	FCC ID	Remarks
A	NFC Tag	SONY	N/A	N/A	N/A	Provided by Lab
B	Earphone	Apple	MB770FE/B	N/A	N/A	Provided by Lab
C	HDD*2	Transcend	ESD350C	F34584-0076	N/A	Provided by Lab
		Transcend	ESD350C	F34584-0112	N/A	Provided by Lab
D	Monitor	ASUS	MX27U	H3LMRS034164	N/A	Provided by Lab
E	Monitor	ASUS	PA279CV	M6LMTF232856	N/A	Provided by Lab
F	IC Card	N/A	N/A	N/A	N/A	Provided by Lab
G	Barcode	N/A	N/A	N/A	N/A	Provided by Lab
H	SD Card	Sony	16GB	N/A	N/A	Provided by Lab
I	Mouse	DELL	MS111-P	CN-011D3V-71581-1CJ-092T	N/A	Provided by Lab
J	Monitor	ASUS	MX27U	J3LMRS000059	N/A	Provided by Lab
K	Laptop	DELL	Latitude E5420	N/A	N/A	Provided by Lab
L	Printer	EPSON	Epson Stylus T22	MEEZ070220	N/A	Provided by Lab
M	HDD*2	Transcend	TS1TSJ25M3G	G02688-0204	N/A	Provided by Lab
		Transcend	TS1TSJ25M3G	G02688-0207	N/A	Provided by Lab
N	Modem	ACEEX	1414V/3	0401008244	N/A	Provided by Lab
O	Bluetooth Earphone	ELECOM	LBT-MPHS400	N/A	N/A	Provided by Lab
P	AP Router	ASUS	GT-AXE 11000	N/A	N/A	Provided by Lab
Q	GPS simulator	T&E	GSG-64	N/A	N/A	Provided by Lab
R	Laptop	DELL	Latitude E5420	N/A	N/A	Provided by Lab
S	Tablet	Getac	K120	N/A	N/A	Supplied by applicant
T	Adapter	Chicony	A20-065N3A	N/A	N/A	Supplied by applicant
U	Touch Pen	Getac	34014200064	N/A	N/A	Supplied by applicant

ID	Cable Descriptions	Qty.	Length (m)	Shielding (Yes/No)	Cores (Qty.)	Remarks
1	Audio	1	1.2	Yes	0	Provided by Lab
2	USB Type C	2	0.5	Yes	0	Provided by Lab
3	HDMI	1	2	Yes	0	HDMI 2.0 (Brand: Amber, Model: HDMI-AA120)
4	DP	1	2	Yes	0	Provided by Lab
5	Power	1	1.7	Yes	0	Supplied by applicant
6	USB	1	1.8	Yes	0	Provided by Lab
7	HDMI	1	2	Yes	0	HDMI 2.0 (Brand: Amber, Model: HDMI-AA120)
8	Cat.5e	1	10	No	0	Provided by Lab
9	USB	1	1.8	Yes	0	Provided by Lab
10	USB	2	0.5	Yes	0	Provided by Lab
11	RS232	1	1.2	Yes	0	Provided by Lab
12	Cat.5e	1	10	No	0	Provided by Lab

4 Test Instruments

The calibration interval of the all test instruments are 12 months and the calibrations are traceable to NML/ROC and NIST/USA.

4.1 Conducted Emissions from Power Ports

Description Manufacturer	Model No.	Serial No.	Calibrated Date	Calibrated Until
50 ohm terminal resistance HUBER+SUHNER	E1-011315	13	2023/11/22	2024/11/21
50 ohm terminal resistance	E1-011279	04	2023/11/22	2024/11/21
	E1-011280	05	2023/11/22	2024/11/21
DC-LISN Schwarzbeck	NNBM 8126G	8126G-069	2023/11/7	2024/11/6
EMI Test Receiver R&S	ESCI	100613	2023/12/4	2024/12/3
Fixed Attenuator Mini-Circuits	HAT-10+	PAD-COND1-01	2024/1/6	2025/1/5
LISN R&S	ENV216	101826	2024/3/25	2025/3/24
	ESH3-Z5	100311	2023/9/6	2024/9/5
RF Coaxial Cable Woken	5D-FB	Cable-cond1-01	2024/1/6	2025/1/5
Software BVADT	BVADT_Cond_ V7.4.1.0	N/A	N/A	N/A
V-LISN Schwarzbeck	NNBL 8226-2	8226-142	2023/8/31	2024/8/30

Notes:

1. The test was performed in HY - Conduction 1.
2. The VCCI Site Registration No. is C-12040.
3. Tested Date: 2024/4/18

4.2 Radiated Emissions up to 1 GHz

Description Manufacturer	Model No.	Serial No.	Calibrated Date	Calibrated Until
Antenna Tower (H)	MFA-440	970705	N/A	N/A
Antenna Tower (V)	MFA-440	9707	N/A	N/A
Bi_Log Antenna Schwarzbeck	VULB 9168	9168-148	2023/12/14	2024/12/13
		9168-156	2023/12/14	2024/12/13
Controller (H)	MF7802	08093	N/A	N/A
Controller (V)	MF7802	074	N/A	N/A
EMI Test Receiver R&S	ESR7	101240	2023/11/9	2024/11/8
		101471	2024/3/13	2025/3/12
Fixed Attenuator Mini-Circuits	UNAT-5+	PAD-CH(H)-01	2023/9/2	2024/9/1
		PAD-CH(V)-01	2023/9/2	2024/9/1
Preamplifier Sonoma	310N	352923	2023/5/7	2024/5/6
		352924	2023/5/7	2024/5/6
RF Coaxial Cable TIMES	LMR-600(11.8M)+LMR-400 (7M)	CABLE-CH1(HOR)-01	2023/9/2	2024/9/1
	LMR-600(18M)+LMR-400 (7M)	CABLE-CH1(VER)-01	2023/9/2	2024/9/1
Software	ADT_Radiated_V8.8.09	N/A	N/A	N/A
Turn Table	DS430	50303	N/A	N/A

Notes:

1. The test was performed in HY - 10M Chamber. The test site validated date: 2023/7/29 (NSA)
2. The VCCI Site Registration No. is R-11893.
3. Tested Date: 2024/4/24

5 Limits of Test Items

5.1 Conducted Emissions from Power Ports

Frequency (MHz)	Class A (dBuV)		Class B (dBuV)	
	Quasi-peak	Average	Quasi-peak	Average
0.15 - 0.5	79	66	66 - 56	56 - 46
0.50 - 5.0	73	60	56	46
5.0 - 30.0	73	60	60	50

Notes: 1. The lower limit shall apply at the transition frequencies.

2. The limit decreases linearly with the logarithm of the frequency in the range of 0.15 to 0.50 MHz.

5.2 Radiated Emissions up to 1 GHz

Emissions radiated outside of the specified bands, shall be according to the general radiated limits as following:

Radiated Emissions Limits at 10 meters (dB μ V/m)				
Frequencies (MHz)	FCC 15B, Class A	FCC 15B, Class B	CISPR 22, Class A	CISPR 22, Class B
30-88	39.1	29.5	40	30
88-216	43.5	33.1		
216-230	46.4	35.6		
230-960				
960-1000	49.5	43.5	47	37

Radiated Emissions Limits at 3 meters (dB μ V/m)				
Frequencies (MHz)	FCC 15B, Class A	FCC 15B, Class B	CISPR 22, Class A	CISPR 22, Class B
30-88	49.5	40.0	50.5	40.5
88-216	54.0	43.5		
216-230	56.9	46.0		
230-960				
960-1000	60.0	54.0	57.5	47.5

Notes: 1. The lower limit shall apply at the transition frequencies.

6.2 Radiated Emissions up to 1 GHz

- a. For the table-top EUT is placed on a 0.8 meter to the top of rotating table; for the floor standing EUT shall be insulated (by insulation of 12 mm) from the horizontal reference ground plane. The rotating table is rotated 360 degrees to determine the position of the highest radiation. If the equipment requires a dedicated ground connection, this shall be provided and bonded to the RGP.
- b. The EUT was set 10 meters away from the interference-receiving antenna, which was mounted on the top of a variable-height antenna tower.
- c. The antenna is a broadband antenna, and its height is varied from one meter to four meters above the ground to determine the maximum value of the field strength. Both horizontal and vertical polarizations of the antenna are set to make the measurement.
- d. For each suspected emission, the EUT was arranged to its worst case and then the antenna was tuned to heights from 1 meter to 4 meters and the rotatable table was turned from 0 degrees to 360 degrees to find the maximum reading.
- e. The test-receiver system was set to quasi-peak detect function and specified bandwidth with maximum hold mode when the test frequency is up to 1 GHz.

Note: The resolution bandwidth and video bandwidth of test receiver/spectrum analyzer is 120kHz for quasi-peak detection (QP) at frequency up to 1GHz.

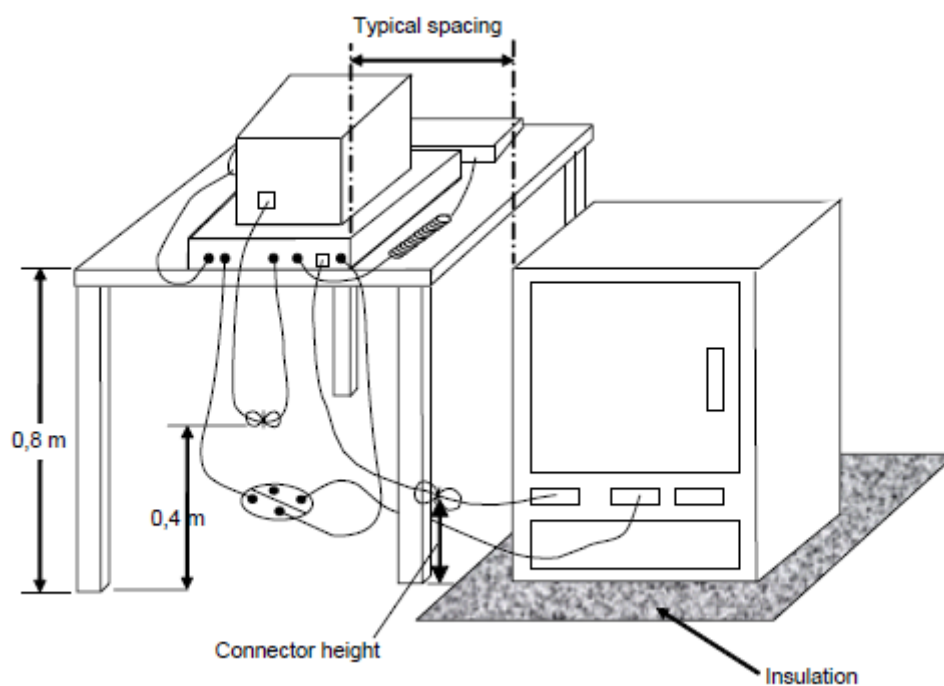

For the actual test configuration, please refer to the related Item – Photographs of the Test Configuration.

7 Test Results of Test Item

7.1 Conducted Emissions from Power Ports

Frequency Range	150 kHz ~ 30 MHz	Detector Function & Resolution Bandwidth	Quasi-Peak (QP) / Average (AV), 9 kHz
Input Power	120 Vac, 60 Hz	Environmental Conditions	21°C, 68% RH, 981.3 mbar
Tested by	Nick Wu		

Phase Of Power : Line (L)										
No	Frequency (MHz)	Correction Factor (dB)	Reading Value (dBuV)		Emission Level (dBuV)		Limit (dBuV)		Margin (dB)	
			Q.P.	AV.	Q.P.	AV.	Q.P.	AV.	Q.P.	AV.
1	0.15000	9.67	36.84	18.45	46.51	28.12	66.00	56.00	-19.49	-27.88
2	0.19400	9.66	37.96	24.55	47.62	34.21	63.86	53.86	-16.24	-19.65
3	0.22600	9.66	30.91	13.95	40.57	23.61	62.60	52.60	-22.03	-28.99
4	0.29800	9.67	30.99	18.61	40.66	28.28	60.30	50.30	-19.64	-22.02
5	0.52600	9.70	24.45	11.20	34.15	20.90	56.00	46.00	-21.85	-25.10
6	10.55400	9.88	24.87	18.77	34.75	28.65	60.00	50.00	-25.25	-21.35
7	13.56000	9.92	33.16	32.35	43.08	42.27	60.00	50.00	-16.92	-7.73

Remarks:

1. Q.P. and AV. are abbreviations of quasi-peak and average individually.
2. The emission levels of other frequencies were very low against the limit.
3. Margin value = Emission level – Limit value
4. Correction factor = Insertion loss + Cable loss
5. Emission Level = Correction Factor + Reading Value

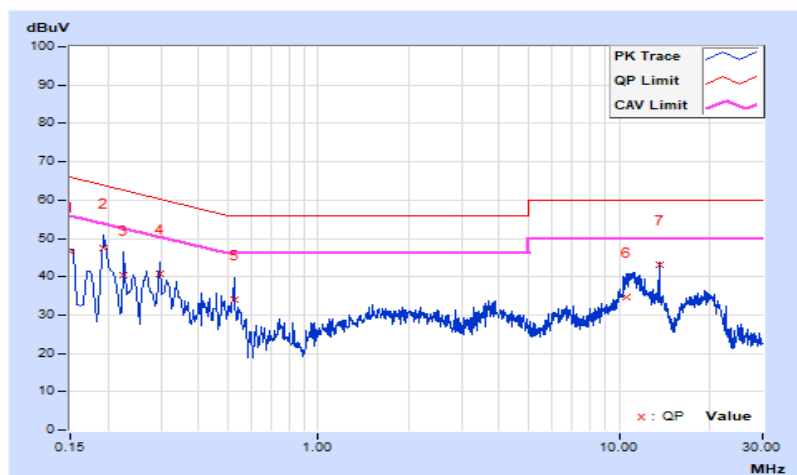

Frequency Range	150 kHz ~ 30 MHz	Detector Function & Resolution Bandwidth	Quasi-Peak (QP) / Average (AV), 9 kHz
Input Power	120 Vac, 60 Hz	Environmental Conditions	21°C, 68% RH, 981.3 mbar
Tested by	Nick Wu		

Phase Of Power : Neutral (N)										
No	Frequency (MHz)	Correction Factor (dB)	Reading Value (dBuV)		Emission Level (dBuV)		Limit (dBuV)		Margin (dB)	
			Q.P.	AV.	Q.P.	AV.	Q.P.	AV.	Q.P.	AV.
1	0.15000	9.64	39.93	24.29	49.57	33.93	66.00	56.00	-16.43	-22.07
2	0.19000	9.65	37.84	23.76	47.49	33.41	64.04	54.04	-16.55	-20.63
3	0.31000	9.68	29.77	21.12	39.45	30.80	59.97	49.97	-20.52	-19.17
4	0.49800	9.71	24.60	15.04	34.31	24.75	56.03	46.03	-21.72	-21.28
5	3.95800	9.78	22.06	11.77	31.84	21.55	56.00	46.00	-24.16	-24.45
6	10.49800	9.95	23.58	16.57	33.53	26.52	60.00	50.00	-26.47	-23.48
7	13.56000	10.02	32.58	32.02	42.60	42.04	60.00	50.00	-17.40	-7.96

Remarks:

1. Q.P. and AV. are abbreviations of quasi-peak and average individually.
2. The emission levels of other frequencies were very low against the limit.
3. Margin value = Emission level – Limit value
4. Correction factor = Insertion loss + Cable loss
5. Emission Level = Correction Factor + Reading Value

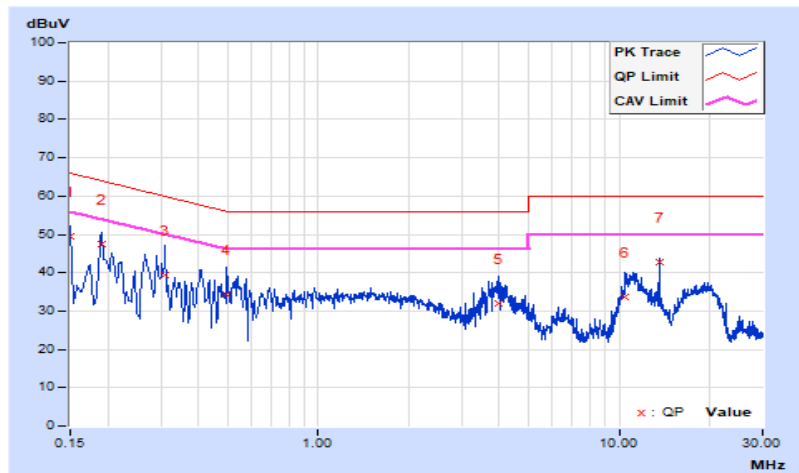

7.2 Radiated Emissions up to 1 GHz

Frequency Range	30 MHz ~ 1 GHz	Detector Function & Resolution Bandwidth	Quasi-Peak (QP), 120 kHz
Input Power	120 Vac, 60 Hz	Environmental Conditions	21°C, 70% RH, 980.7 mbar
Tested By	Rene Chen		

Antenna Polarity & Test Distance : Horizontal at 10 m								
No	Frequency (MHz)	Emission Level (dBuV/m)	Limit (dBuV/m)	Margin (dB)	Antenna Height (m)	Table Angle (Degree)	Raw Value (dBuV)	Correction Factor (dB/m)
1	191.08	21.76 QP	30.00	-8.24	3.00 H	238	37.04	-15.28
2	298.33	26.65 QP	37.00	-10.35	3.00 H	356	39.09	-12.44
3	352.59	28.96 QP	37.00	-8.04	3.00 H	159	40.17	-11.21
4	366.14	28.12 QP	37.00	-8.88	2.00 H	166	38.85	-10.73
5	479.98	26.04 QP	37.00	-10.96	2.00 H	327	33.95	-7.91
6	978.08	31.86 QP	37.00	-5.14	1.00 H	268	30.05	1.81

Remarks:

1. Emission Level(dBuV/m) = Raw Value(dBuV) + Correction Factor(dB/m)
2. Correction Factor(dB/m) = Antenna Factor (dB/m) + Cable Factor (dB)
– Pre-Amplifier Factor (dB)
3. Margin value = Emission level – Limit value
4. The other emission levels were very low against the limit.

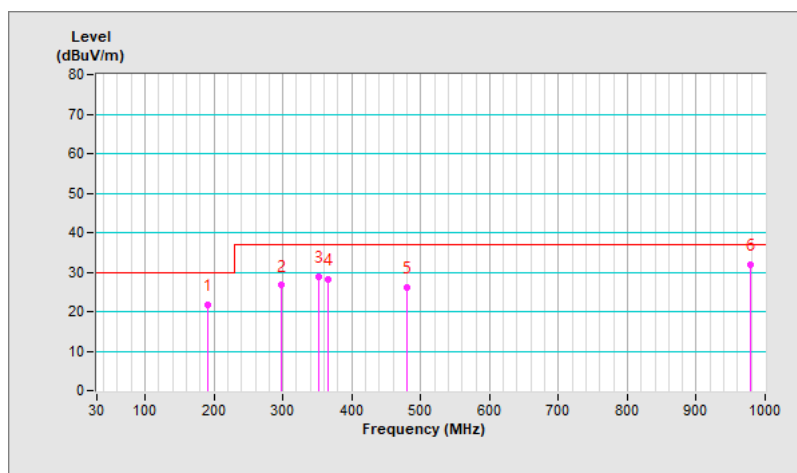

Frequency Range	30 MHz ~ 1 GHz	Detector Function & Resolution Bandwidth	Quasi-Peak (QP), 120 kHz
Input Power	120 Vac, 60 Hz	Environmental Conditions	21°C, 70% RH, 980.7 mbar
Tested By	Rene Chen		

Antenna Polarity & Test Distance : Vertical at 10 m								
No	Frequency (MHz)	Emission Level (dBuV/m)	Limit (dBuV/m)	Margin (dB)	Antenna Height (m)	Table Angle (Degree)	Raw Value (dBuV)	Correction Factor (dB/m)
1	40.67	23.80 QP	30.00	-6.20	2.00 V	159	37.20	-13.40
2	76.27	23.69 QP	30.00	-6.31	3.00 V	96	39.98	-16.29
3	122.02	22.24 QP	30.00	-7.76	2.00 V	342	37.53	-15.29
4	148.50	26.62 QP	30.00	-3.38	2.00 V	198	39.98	-13.36
5	271.21	26.03 QP	37.00	-10.97	1.00 V	161	39.38	-13.35
6	352.59	28.70 QP	37.00	-8.30	4.00 V	254	40.06	-11.36
7	990.53	31.87 QP	37.00	-5.13	3.00 V	93	29.79	2.08

Remarks:

1. Emission Level(dBuV/m) = Raw Value(dBuV) + Correction Factor(dB/m)
2. Correction Factor(dB/m) = Antenna Factor (dB/m) + Cable Factor (dB) – Pre-Amplifier Factor (dB)
3. Margin value = Emission level – Limit value
4. The other emission levels were very low against the limit.

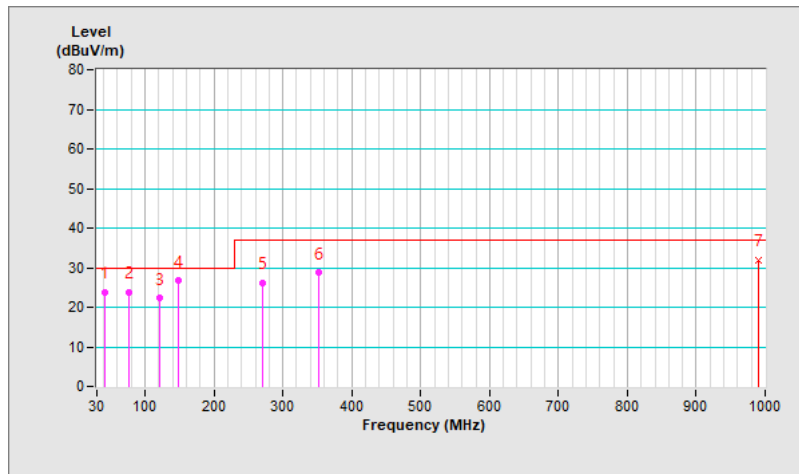

8 Pictures of Test Arrangements

8.1 Conducted Emissions from Power Ports



8.2 Radiated Emissions up to 1 GHz

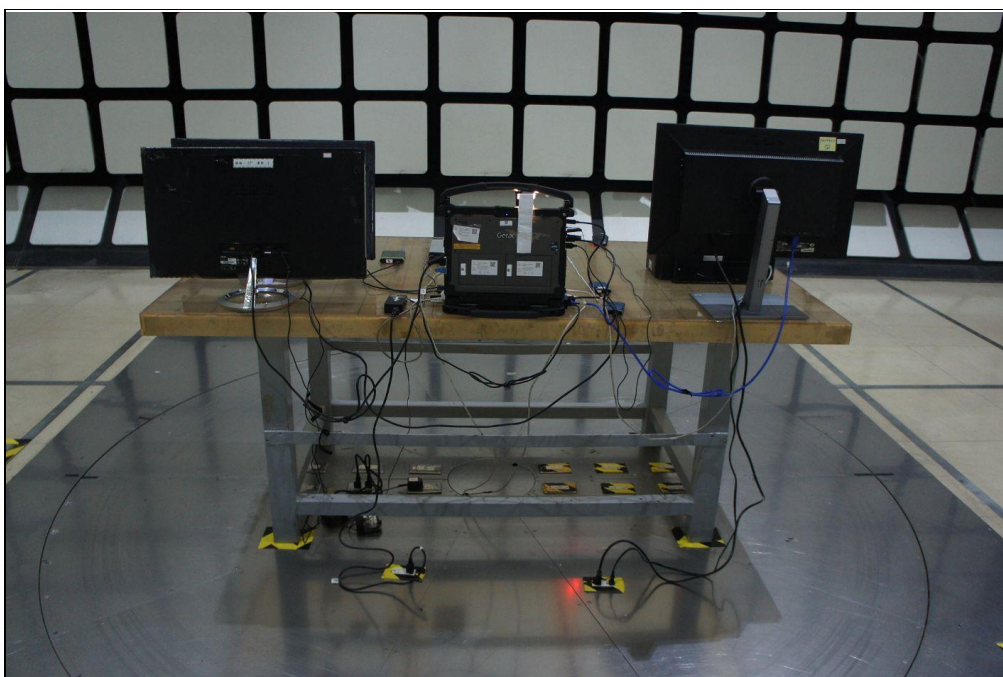

9 Information of the Testing Laboratories

We, Bureau Veritas Consumer Products Services (H.K.) Ltd., Taoyuan Branch, were founded in 1988 to provide our best service in EMC, Radio, Telecom and Safety consultation. Our laboratories are FCC recognized accredited test firms and accredited according to ISO/IEC 17025.

If you have any comments, please feel free to contact us at the following:

Lin Kou EMC/RF Lab

Tel: 886-2-26052180

Fax: 886-2-26051924

Hsin Chu EMC/RF/Telecom Lab

Tel: 886-3-6668565

Fax: 886-3-6668323

Hwa Ya EMC/RF/Safety Lab

Tel: 886-3-3183232

Fax: 886-3-3270892

Email: service.adt@bureauveritas.com

Web Site: <http://ee.bureauveritas.com.tw>

The address and road map of all our labs can be found in our web site also.

--- END ---